

**MS2024A/MS2026A**  
**VNA Master**  
**MAINTENANCE MANUAL**



## Table of Contents

1. Introduction .....	1
2. Description .....	1
3. Recommended Test Equipment .....	1
4. Performance Verification .....	2
Frequency Accuracy .....	2
Port Isolation .....	2
Return Loss Verification .....	5
Power Monitor (Option 5) Verification .....	6
Bias Tee (Option 10) Verification .....	7
GPS (Option 31) Operational Check .....	8
5. Battery Information .....	9
6. Battery Pack Removal and Replacement .....	10
7. Removal and Replacement Procedures for Internal Assemblies .....	12
Opening the VNA Master Case .....	12
Removal and Replacement of the Option 5 Power Monitor PCB .....	13
Removal and Replacement of the VNA Module Assembly .....	14
Real Time Clock (RTC) Battery Removal and Replacement .....	15
Main PCB Assembly Replacement .....	16
LCD Assembly Replacement .....	18
LCD Backlight PCB Removal and Replacement .....	19
Keypad Membrane and PCB Replacement .....	20
Function Key Membrane and Switchpad Replacement .....	22
8. Accessories and Replaceable Parts List .....	23
9. ANRITSU Customer Service Centers .....	25



## 1. Introduction

This manual provides maintenance instructions for the VNA Master MS202xA. It describes the product and provides performance verification procedures, parts replacement procedures, and a replaceable parts list.

## 2. Description

The MS2024A and MS2026A VNA Masters are handheld Vector Network Analyzers designed to make accurate vector corrected 1-port magnitude, phase, and fault location measurements and 1-path, 2-port magnitude and phase measurements from 2 MHz to 6 GHz.

RF immunity rejection up to +17 dBm allows for accurate measurements in RF rich environments. More than 1000 traces and setups can be stored in internal memory and data can be transferred to a computer via Ethernet, USB, or memory card.

### Frequency Ranges

MS2024A 2 MHz to 4 GHz

MS2026A 2 MHz to 6 GHz

## 3. Recommended Test Equipment

The following test equipment is recommended for use in testing and maintaining the VNA Master.

NOTE: Verify that the test equipment is operating properly before it is used.

**Table 1.** Recommended Test Equipment

Equipment	Critical Specification	Recommended Manufacturer/Model
Synthesizer	Frequency: 1 GHz with options 2A, 4 (or 5), and 15A	Anritsu Model MG3691A
Power Meter	Power Range: -70 to +20 dBm	Anritsu Dual Channel Model ML2437A
Power Sensor	Frequency: 10 MHz to 18 GHz, Range: -67 to +20 dB	Anritsu Model MA2442D
Frequency Reference	Frequency: 10 MHz	Absolute Time Corp., Model 300
Power Splitter	Frequency: DC to 18 GHz	Weinschel Model 1870A
Adapter	Frequency: 1 GHz K(m) to N(f)	Anritsu Model 34RKNF50
RF Coaxial Cable	Frequency: DC to 6.0 GHz N(m)-N(m), 50 Ohm	Anritsu Model 15NN50-1.5C
RF Detector (for Option 5)	Frequency: 10 MHz to 20 GHz	Anritsu Model 560-7N50B
High Current Test Fixture (for Option 10)	Resistance: 40 Ohm Power: 5 Watts	Anritsu Model T2904
Low Current Test Fixture (for Option 10)	Resistance: 105 Ohm Power: 1 Watt	Anritsu Model T3377
Frequency Counter	Frequency: 2 GHz	Anritsu Model MF2412B
Open/Short		Anritsu Part Number 22N50
Termination	Frequency: DC to 18 GHz Return Loss: 40 dB min	Anritsu Model 28N50-2
Termination	Frequency: DC to 18 GHz Return Loss: 40 dB min	Anritsu Model 28NF50-2
Offset Termination	Frequency: DC to 6 GHz Return Loss: 6 dB $\pm$ .35 dB	Anritsu Model SC7424
Offset Termination	Frequency: DC to 6 GHz Return Loss: 20 dB $\pm$ 1.0 dB	Anritsu Model SC7423

## 4. Performance Verification

The following tests can be used to verify the performance or operation of the VNA Master.

### 4.1 Frequency Accuracy

The following test can be used to verify the CW frequency accuracy of the VNA Master. Measurement calibration of the VNA is not required for this test.

#### Equipment Required:

- VNA Master External Power Supply, Anritsu Part Number 40-168
- Frequency Counter, Anritsu Model MF2412B
- RF Coaxial Cable, Anritsu Model 15NN50-1.5C

#### Procedure:

1. Connect the external power supply (Anritsu part number 40-168) to the VNA Master.
2. Press the **On/Off** key to turn on the VNA Master.
3. Press the **Shift** key, the **Preset** key (1), and then the **Preset** soft key to reset the instrument to the default starting conditions.

**NOTE:** Before continuing, allow a 30-minute warm up for the internal circuitry to stabilize.

4. Press the **Measurement** key, then press the **S21 Transmission** soft key. Verify that the **Log Magnitude** soft key is selected (there will be a red dot on the key label). If not, select the **Log Magnitude** soft key.
5. Press the **Shift** key, then press the **Sweep** (3) key.
6. Verify that the **RF Immunity** is set to **Normal** (the word **Normal** will be underlined on the soft key label). If not, press the **RF Immunity** soft key to set the instrument to **Normal**.
7. Press the **Freq/Dist** key, then press the **Start Freq** soft key.
8. Verify that the **Start Frequency** is set to 2 GHz. If not, enter 2 then press the **GHZ** soft key to set the **Start Frequency** to 2 GHz.
9. Press the **Stop Freq** soft key.
10. Using the keypad, enter 2 and press the **GHZ** soft key to set the **Stop Frequency** to 2 GHz.
11. Connect the RF cable from the VNA Master **RF Out** test port to the **RF Input1** connector on the **Frequency Counter**.
12. Turn on the **Frequency Counter** and press the **Preset** key.
13. Verify that **Frequency Counter** reading is 2 GHz,  $\pm 50$  KHz.

### 4.2 Port Isolation

The following test can be used to verify the transmission test port isolation. Measurement calibration of the VNA Master is required for this test.

#### Equipment Required:

- 50 Ohm Termination, Anritsu Model 28N50-2
- 50 Ohm Termination, Anritsu Model 28NF50-2
- Open/Short, Anritsu Part Number 22N50
- VNA Master External Power Supply, Anritsu Part Number 40-168
- RF Coaxial Cable, Anritsu Model 15NN50-1.5C

#### Procedure:

1. Connect the external power supply (Anritsu part number 40-168) to the VNA Master.
2. Press the **On/Off** key to turn on the VNA Master.

3. Press the **Shift** key, the **Preset** key (1), and then the **Preset** soft key to reset the instrument to the default starting conditions.

**NOTE:** Before continuing, allow a 30-minute warm up for the internal circuitry to stabilize.

4. Press the **Measurement** key, then press the **S21 Transmission** soft key. Verify that the **Log Magnitude** soft key is selected (there will be a red dot on the key label). If not, select the **Log Magnitude** soft key.
5. Press the **Shift** key, then press the **Sweep** (3) key.
6. Verify that the **RF Immunity** is set to **High** (the word **High** will be underlined on the soft key label). If not, press the **RF Immunity** soft key to set the instrument to **High**.
7. Press the **Scale** key, then press **Reference Value** soft key.
8. Use the keypad to enter **-80**, then press the **dB** soft key.
9. Press the **Resolution Per Div** soft key and use the keypad to enter **5**, then press the **dB** soft key.
10. Press the **Shift** key, then press the **Calibrate** (2) key.
11. Verify that the **Cal Type** is set to **2-Port** and the **Cal Power** is set to **High**. If not, select the soft key to change the setting.
12. Press the **Start Cal** soft key and follow the on screen instructions to perform an OSL-THRU-ISOL calibration using the 22N50 Open/Short, 28NF50-2 and 28NF50-2 Terminations, and the 15NN50-1.5C Test Port Extension Cable (refer to Figure 1).

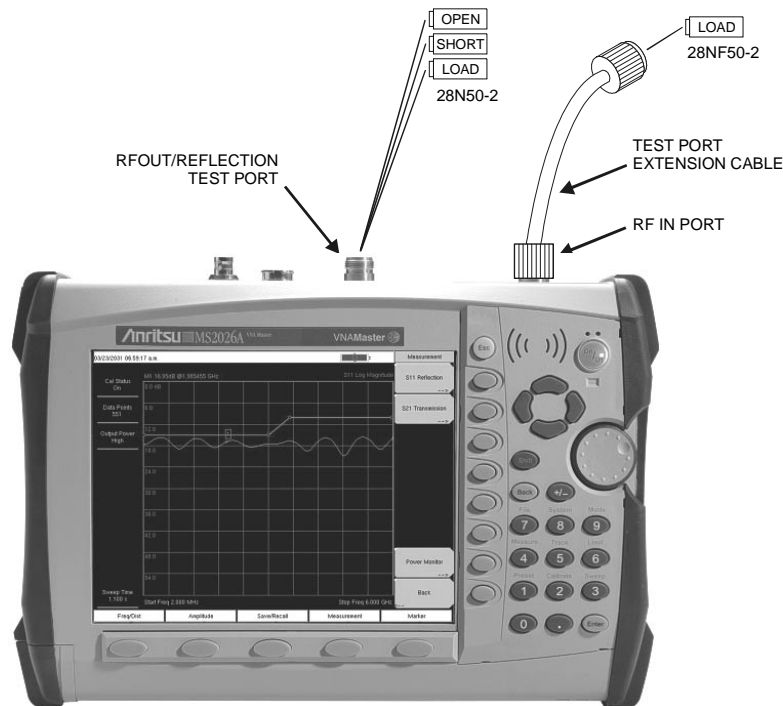

**Figure 1.** OSL-Thru-ISOL Calibration Setup

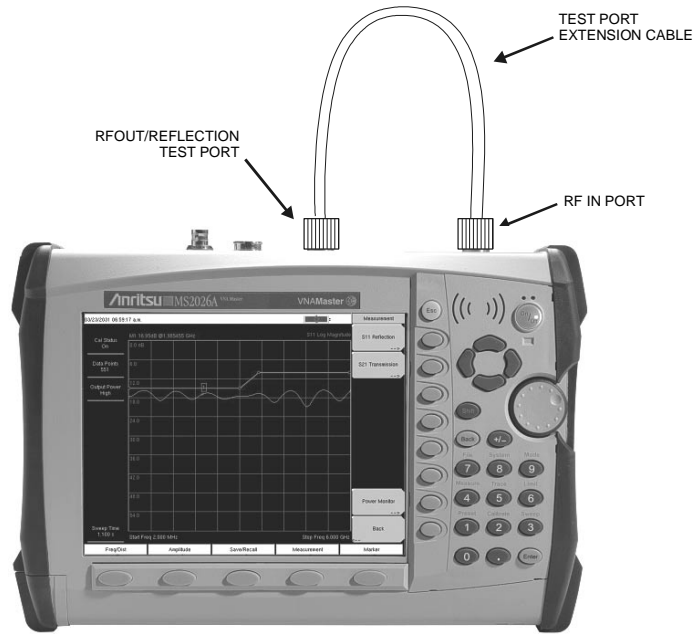

**Figure 2.** Test Setup

13. Disconnect the cable from the RF Out/Reflection Port, connect a 28NF50-2 Load to the cable, and connect a 28N50-2 Load to the RF Out/Reflection Port.
14. Press the **Shift** key, then press the **Limit** (6) key.
15. Press the On/Off soft key to set the limit line to On.
16. Press the Limit Edit soft key and verify that the frequency is set to 2 MHz.
17. Press the Amplitude soft key, use the keypad to enter -80, then press the dB soft key.
18. Press the Add Point soft key, then use the keypad to enter 3 and press the GHz soft key.
19. Press the Amplitude soft key, use the keypad to enter -80, then press the dB soft key.
20. Press the Add Point soft key, then press the Frequency soft key.
21. Use the keypad to enter 3 and press the GHz soft key.
22. Press the Amplitude soft key, use the keypad to enter -70, then press the dB soft key.
23. Press the Add Point soft key, then press the Frequency soft key.
24. Use the keypad to enter 5.5 and press the GHz soft key.
25. Press the Amplitude soft key, use the keypad to enter -70, then press the dB soft key.
26. Press the Add Point soft key, then press the Frequency soft key.
27. Use the keypad to enter 5.5 and press the GHz soft key.
28. Press the Amplitude soft key, use the keypad to enter -65, then press the dB soft key.
29. Press the Next Point Right soft key.
30. Verify that the Frequency is set to 6 GHz.
31. Press the Amplitude soft key, use the keypad to enter -65, then press the dB soft key.



32. Verify that the noise floor is below the limit line.

**Table 2** 2-Port Isolation Specification

Frequency Range	Dynamic Range (dB)
2 MHz to 3 GHz	80
3 GHz to 5.5 GHz	70
5.5 GHz to 6 GHz	65

### 4.3 Return Loss Verification

The following test can be used to verify the accuracy of return loss measurements. Measurement calibration of the VNA Master is required for this test.

#### Equipment Required:

- 20 dB offset, Anritsu SC7423
- 6 dB offset, Anritsu SC7424
- Open/Short, Anritsu 22N50
- 50 Ohm Termination, Anritsu 28N50-2
- VNA Master External Power Supply, Anritsu Part Number 40-168

#### Procedure:

1. Connect the external power supply (Anritsu part number 40-168) to the VNA Master.
2. Press the **On/Off** key to turn on the VNA Master.
3. Press the **Shift** key, the **Preset** key (1), and then the **Preset** soft key to reset the instrument to the default starting conditions.

NOTE: Before continuing, allow a 30-minute warm up for the internal circuitry to stabilize.

4. Press the **Measurement** key, then press the **S11 Reflection** soft key. Verify that the **Log Magnitude** soft key is selected (there will be a red dot on the key label). If not, select the **Log Magnitude** soft key.
5. Press the **Shift** key, then press the **Calibrate** (2) key. Verify that the **Type** is set to 1-Port and **Cal Power** is High.
6. Press the **Start Cal** soft key. Follow the instructions on the screen to perform a calibration using a 22N50 Open/Short and 28N50-2 Termination.
7. Press the **Scale** key, then press **Reference Value** soft key. Use the keypad to enter 20, then press the **dB** soft key.
8. Press the **Resolution Per Div** soft key. Use the keypad to enter .4, then press the **dB** soft key.
9. Connect the 20 dB offset to the **RF Out** test port.
10. Press the **Marker** key and select the **Peak Search** soft key and record the Marker value.
11. Press the **Valley Search** soft key and record the Marker value.
12. Verify that both the Peak and Valley readings are within  $20 \pm 1.61$  dB.
13. Disconnect the 20 dB offset.
14. Press the **Scale** key, then press the **Reference Value** soft key. Use the keypad to enter 6, then press the **dB** soft key.
15. Press the **Resolution Per Div** soft key. Use the keypad to enter 0.2, then press the **dB** soft key.
16. Connect the 6 dB offset to the **RF Out** test port.
17. Press the **Marker** key and select the **Peak Search** soft key and record the Marker value.
18. Press the **Valley Search** soft key and record the Marker value.
19. Verify that both the Peak and Valley readings are within  $6 \pm 0.95$  dB.

## 4.4 Power Monitor (Option 5) Verification

If the Power Monitor (Option 5) is installed in the VNA Master, the following test can be used to verify the accuracy of the power measurements.

### Equipment Required:

- Anritsu MG3691A Synthesized Signal Source with options 2A, 4 (or 5), and 15A
- Power Meter, Anritsu Model ML2437A
- Power Sensor, Anritsu Model MA2442D
- RF Detector, Anritsu 560-7N50B
- Power Splitter, Weinschel Model 1870A
- RF Coaxial Cable, Anritsu Model 15NN50-1.5C
- Adapter, Anritsu Model 34RKNF50
- VNA Master External Power Supply, Anritsu Part Number 40-168

### Procedure

1. Connect the external power supply (Anritsu part number 40-168) to the VNA Master.
2. Press the **On/Off** key to turn on the VNA Master.
3. Press the **Shift** key, the **Preset** key (1), and then the **Preset** soft key to reset the instrument to the default starting conditions.

**NOTE:** Before continuing, allow a 30-minute warm up for the internal circuitry to stabilize.

4. Set the MG3691A output to 1.0 GHz.
5. Connect the power sensor to the power meter and calibrate the sensor.
6. Connect MG3691A, power meter, RF detector, and sensor as shown in Figure 3.

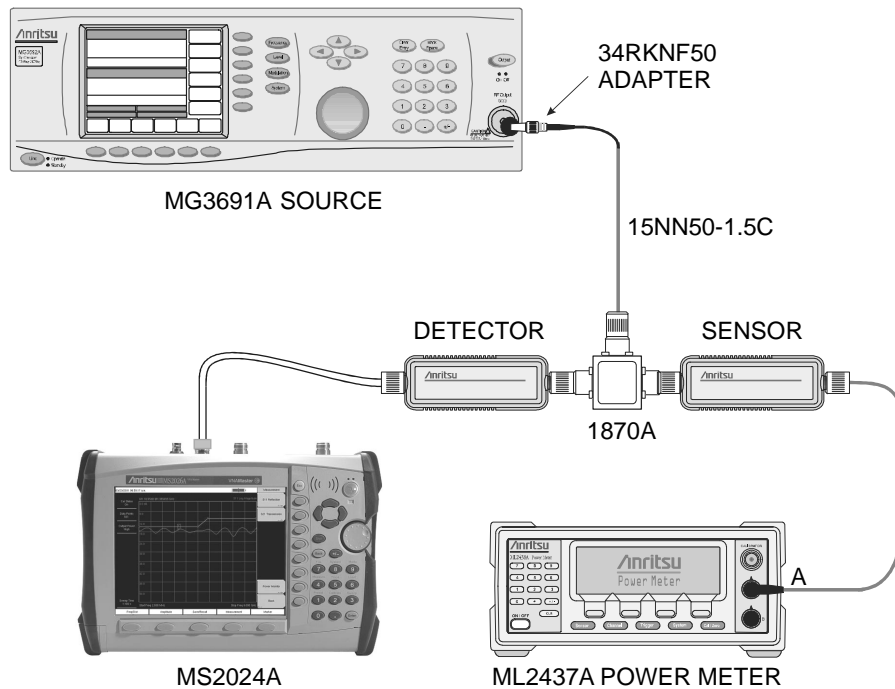

**Figure 3.** Power Monitor Verification Test Setup

7. Press the *Freq/Dist* key, and select the **Start Freq** soft key. Using the keypad, enter 1, then press the **GHZ** soft key.
8. Press the **Stop Freq** soft key. Using the keypad, enter 1, then press the **GHZ** soft key.
9. Press the **Measurement** key and select the **Power Monitor** soft key.
10. On the MG3691A press the **Level** key, then use the knob to adjust the power level so that the power meter reads -40 dBm.
11. Verify that the VNA Master reading is  $40 \pm 1.0$  dBm.
12. Repeat steps 10 and 11 for the other power level settings shown in Table 3.

**Table 3** Power Monitor Verification

Power Level (dB)	Spec (dB)
-40	$\pm 1.0$
-21	
-4	
0	
+13	

#### 4.5 Bias Tee (Option 10) Verification

If the Bias Tee (Option 10) is installed in the VNA Master, the following test can be used to verify the performance of the bias termination.

##### Equipment Required:

- 105 Ohm, 1 Watt, Low Current Load, Anritsu T3377
- 40 Ohm, 5 Watt, High Current Load, Anritsu T2904
- VNA Master External Power Supply, Anritsu Part Number 40-168

##### Procedure:

1. Connect the external power supply (Anritsu part number 40-168) to the VNA Master.
2. Press the **On/Off** key to turn on the VNA Master.
3. Press the **Shift** key, the **Preset** key (1), and then the **PreSet** soft key to reset the instrument to the default starting conditions.

NOTE: Before continuing, allow a 30-minute warm up for the internal circuitry to stabilize.

4. Press the **Shift** key, and then the **Sweep** (3) key.

##### Low Current Test

1. Press the **Bias Tee** soft key and verify that the **12V** soft key is selected and the **Current** soft key is set to **Low**.
2. Press the **Bias Tee On/Off** soft key to turn the Bias Tee **On**.
3. Connect the 105 Ohm load to the RF In test port.
4. Verify the voltage and current readings displayed on the left side of the screen are within the specifications shown in Table 4.
5. Select each of the voltage setting soft keys and verify the voltage and current readings displayed on the left side of the screen are within the specifications shown in Table 4.

**Table 4** Bias Tee Verification, 105 Ohm Load, Low Current

Voltage Setting (V)	12	15	18	21	25
Voltage Specification (V)	$\pm 0.5$	$\pm 0.6$	$\pm 0.7$	$\pm 0.8$	$\pm 1.0$
Current Specification (mA)	85-145	113-173	142-202	172-230	199-259

## High Current Test

1. Press the **Current** soft key and set the Bias Tee current to **High**.
2. Verify the voltage and current readings displayed on the left side of the screen are within the specifications shown in Table 5.
3. Select the **15V** soft key and verify the voltage and current readings displayed on the left side of the screen are within the specifications shown in Table 5.

**Table 5** Bias Tee Verification, 105 Ohm Load, High Current

Voltage Setting (V)	12	15
Voltage Specification (V)	$\pm 0.5$	$\pm 0.6$
Current Specification (mA)	85-145	113-173

4. Disconnect the 105 Ohm load and connect the 40 Ohm load to the RF In port.
5. Select the **12V** soft key and verify the voltage and current readings displayed on the left side of the screen are within the specifications shown in Table 6.
6. Select the **15V** soft key and verify the voltage and current readings displayed on the left side of the screen are within the specifications shown in Table 6.

**Table 6** Bias Tee Verification, 40 Ohm Load, High Current

Voltage Setting (V)	12	15
Voltage Specification (V)	$\pm 0.5$	$\pm 0.6$
Current Specification (mA)	25-350	325-425

## Fault Test

1. Press the **Current** soft key and set the Bias Tee current to **Low**.
2. Select the **15V** soft key.
3. Connect the 40 Ohm load to the RF In port.
4. Verify that the instrument makes a clicking sound and the Bias Tee current reading displayed on the left side of the screen is 0 mA.

## 4.6 GPS (Option 31) Operational Check

The following test can be used to verify the operation of the GPS option.

### Equipment Required:

- VNA Master External Power Supply, Anritsu Part Number 40-168
- Anritsu 2000-1410 Magnet Mount GPS Antenna or equivalent

### Procedure:

1. Connect the external power supply (Anritsu part number 40-168) to the VNA Master.
2. Press the **On/Off** key to turn on the VNA Master.
3. Press the **Shift** key, the **Preset** key (1), and then the **Preset** soft key to reset the instrument to the default starting conditions.

**NOTE:** Before continuing, allow a 30-minute warm up for the internal circuitry to stabilize.

4. Connect the GPS antenna to the GPS Antenna connector on the VNA Master.
5. Press the **Shift** key, and then press the **System** (8) key.
6. Press the **GPS** soft key, then press the **GPS On/Off** soft key to turn the GPS **On**.
7. When the GPS fix is acquired, the GPS indicator at the top of the screen will turn green.
8. Press the **GPS Info** soft key to view the latitude, longitude, altitude, and other GPS information.

## 5. Battery Information

The following information relates to the care and handling of the VNA Master battery, and Lithium-Ion batteries in general.

- The battery supplied with the VNA Master may need charging before use. Before using the VNA Master, the internal battery may be charged either in the VNA Master, using either the AC-DC Adapter (40-168) or the 12-Volt DC adapter (806-62), or separately in the optional Dual Battery Charger (2000-1374).
- Use only Anritsu approved battery packs.
- Recharge the battery only in the VNA Master or in an Anritsu approved charger.
- When the VNA Master or the charger is not in use, disconnect it from the power source.
- Do not charge batteries for longer than 24 hours; overcharging may shorten battery life.
- If left unused a fully charged battery will discharge itself over time.
- Temperature extremes affect the ability of the battery to charge: allow the battery to cool down or warm up as necessary before use or charging.
- Discharge the battery from time to time to improve battery performance and battery life.
- The battery can be charged and discharged hundreds of times, but it will eventually wear out.
- The battery may need to be replaced when the operating time between charging becomes noticeably shorter than normal.
- Never use a damaged or worn out charger or battery.
- Storing the battery in extreme hot or cold places will reduce the capacity and lifetime of the battery.
- Never short-circuit the battery terminals.
- Do not drop, mutilate or attempt to disassemble the battery.
- Do not dispose of batteries in a fire!
- Batteries must be recycled or disposed of properly. Do not place batteries in household garbage.
- Always use the battery for its intended purpose only.

## 6. Battery Pack Removal and Replacement

This section provides instructions for the removal and replacing the VNA Master battery pack.

**NOTE:** Many of the procedures in this section are generic, and apply to many similar instruments. Photos and illustrations used are representative and may show instruments other than the VNA Master.

1. With the VNA Master laying flat, face up, on a stable surface, locate the battery access door, as illustrated in Figure 4.



**Figure 4.** Battery Access Door Location

2. Place a finger in the battery access door notch and push the door down towards the bottom of the instrument, as illustrated in Figure 5.

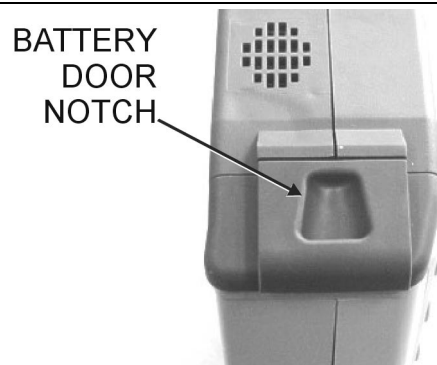

**Figure 5.** Battery Access Door Notch

3. Remove the battery access door, as illustrated in Figure 6.

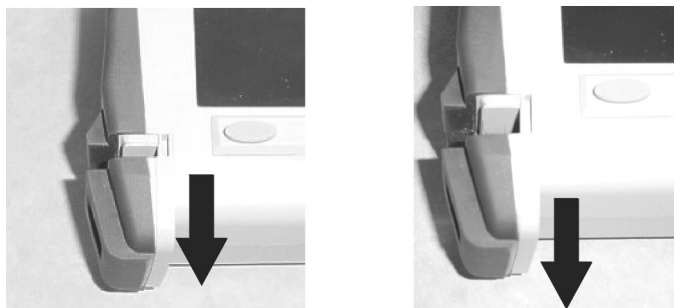

**Figure 6.** Removing the Battery Access Door

4. With the battery access door completely removed, grasp the battery lanyard and pull the battery straight out of the unit, as illustrated in Figure 7.



**Figure 7.** Removing the Battery

5. Replacement is the opposite of removal. Note the orientation of the battery contacts, and be sure to insert the new battery with the contacts facing the bottom of the unit, as illustrated in Figure 8.

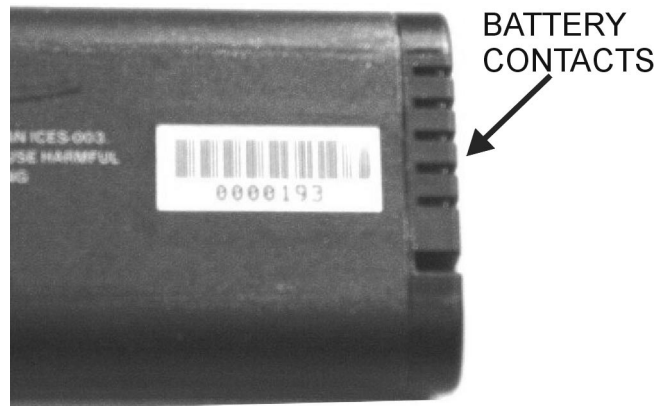

**Figure 8.** Battery Contacts

## 7. Removal and Replacement Procedures for Internal Assemblies

### 7.1 Opening the VNA Master Case

This procedure provides instructions for opening the VNA Master case. With the case opened, the internal assemblies can be removed and replaced, as detailed in the following sections.

1. Place the VNA Master face down on a stable work surface.
2. Remove the battery door and battery as shown on page 10, Battery Pack Removal and Replacement.
3. Use a Phillips screwdriver to remove the four screws securing the two halves of the VNA Master case together (Figure 9).

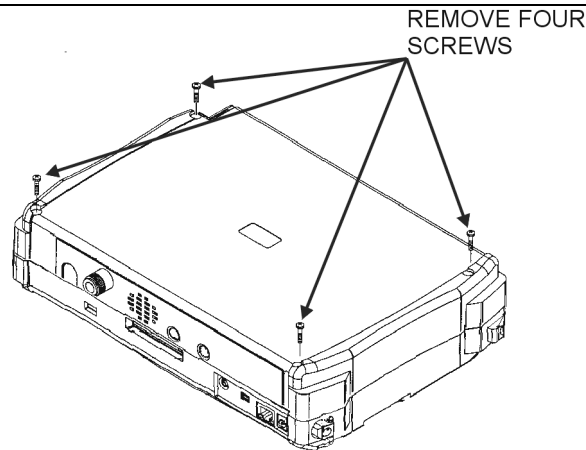

**Figure 9.** Removing the Cover Screws

4. Carefully lift up on the sides and remove the back half of the case.
5. Replacement is the opposite of removal.

**NOTE:** There is an RF gasket material between the two halves of the case, and in the connector panel grooves. Take care not to remove or damage this material when removing or replacing the back half of the case.



## 7.2 Removal and Replacement of the Option 5 Power Monitor PCB

This procedure details the removal and replacement of the Power Monitor PCB Assembly (ND65233).

1. Refer to page 12, Opening the VNA Master Case to expose the Power Monitor PCB.
2. Carefully disconnect the connector ribbon cable from the Power Monitor PCB connection marked P1.

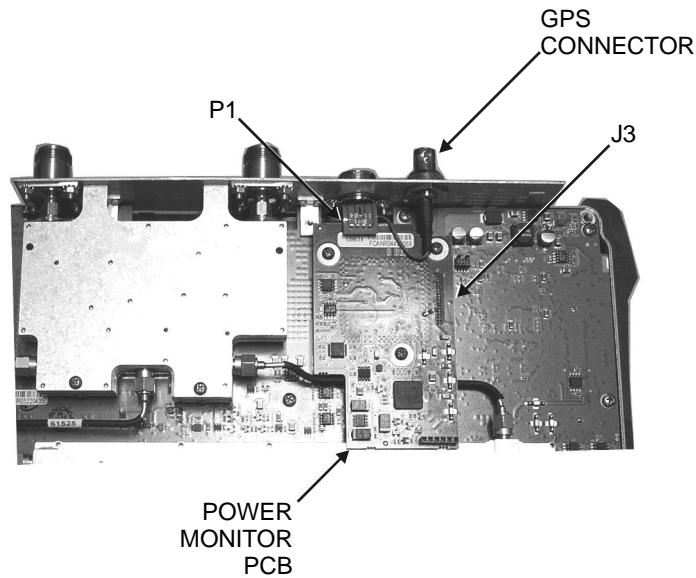

**Figure 10.** Power Monitor PCB

3. Use a Phillips screwdriver to remove the three Phillips screws that secure the Power Monitor PCB to the VNA Module PCB.
4. Carefully lift up and disconnect the Power Monitor PCB from the VNA Module PCB connector J3, under the board.

**NOTE:** It may be necessary to temporarily remove the Option 31 GPS connector (if so equipped) from the connector panel to allow enough clearance to remove or replace the Power Monitor PCB.

5. Reverse the above steps to replace the Power Monitor PCB.

### 7.3 Removal and Replacement of the VNA Module Assembly

This procedure details the removal and replacement of the VNA Module Assembly (ND65232).

1. Refer to page 12, Opening the VNA Master Case to expose the VNA Module Assembly.
2. Use a Phillips screwdriver to remove the nine Phillips screws that secure the VNA Module PCB to the case.

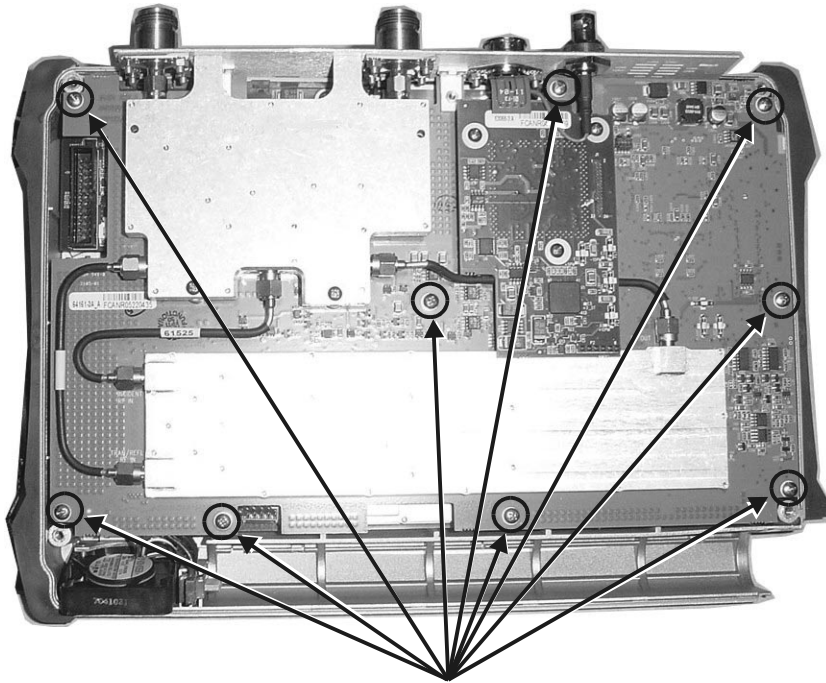

**REMOVE  
SCREWS**

**Figure 11.** VNA Module PCB

3. Lift the VNA Module PCB and carefully disconnect the cable from the 100M AUX connector on the Main PCB assembly. Remove the VNA Module PCB.

**NOTE:** Remove the Option 31 GPS connector (if so equipped) from the connector panel. The GPS connector wire remains connected to the GPS module on the Main PCB assembly, below the VNA Module PCB. Slide the wire between the connector panel and the board to allow removal of the VNA Module PCB.

4. Reverse the above steps to replace the VNA Module PCB.

## 7.4 Real Time Clock (RTC) Battery Removal and Replacement

This procedure provides instructions for removal and replacement of the Real Time Clock (RTC) lithium coin battery (633-26).

1. Refer to page 12, Opening the VNA Master Case and remove the back cover.
2. Refer to page 14, Removal and Replacement of the VNA Module Assembly and remove the VNA Module PCB.
3. Locate the RTC battery, as shown below.

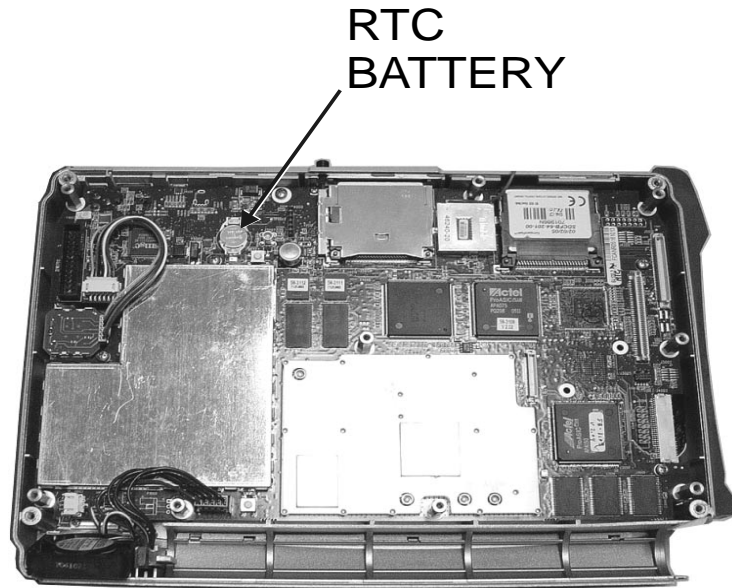

**Figure 12.** RTC Lithium Battery on the Main PCB

4. Using a non-metallic probe, gently pry the battery from its holder, taking care not to damage the holder or surrounding components.

**NOTE:** The RTC battery may be secured in the holder with a small quantity of clear RTV sealant on top of the battery. Replace this sealant when replacing the battery to insure that the battery remains properly secured. Do not allow the sealant to come between the battery and the holder contacts.

5. Install the new RTC battery, making sure that the positive (+) side of the battery faces up.

## 7.5 Main PCB Assembly Replacement

This procedure provides instructions for replacing the Main PCB assembly. The Main PCB assembly is located in the front panel half of the instrument.

1. Refer to page 12, Opening the VNA Master Case and remove the back cover.
2. Refer to page 14, Removal and Replacement of the VNA Module Assembly and remove the VNA Module PCB.
3. Disconnect the Fan connector at J1002 on the Main PCB assembly.
4. Disconnect the Encoder Knob connector at J5010 on the Main PCB assembly.
5. Disconnect the Battery connector from J1003 on the main PCB assembly.

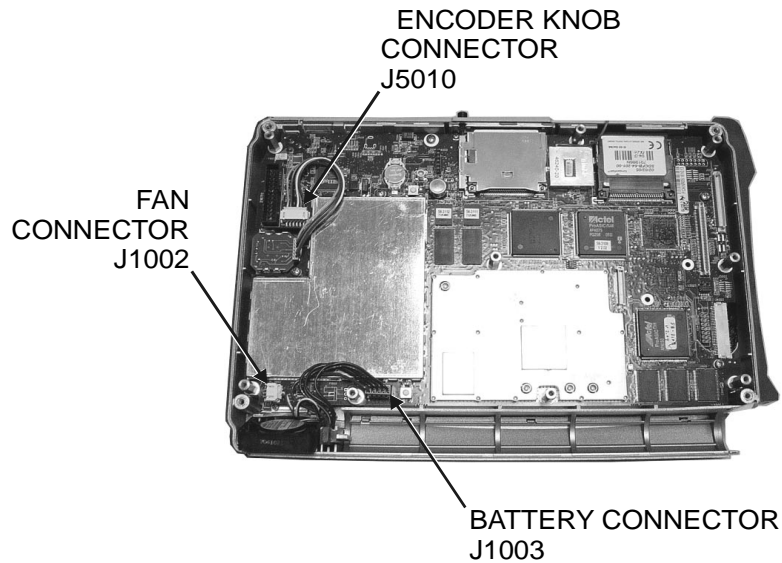

**Figure 13.** Main PCB Assembly Connectors

6. Use a Phillips screwdriver and a .25" nut driver to remove the two screws and seven standoffs securing the main PCB assembly to the Front Panel section.

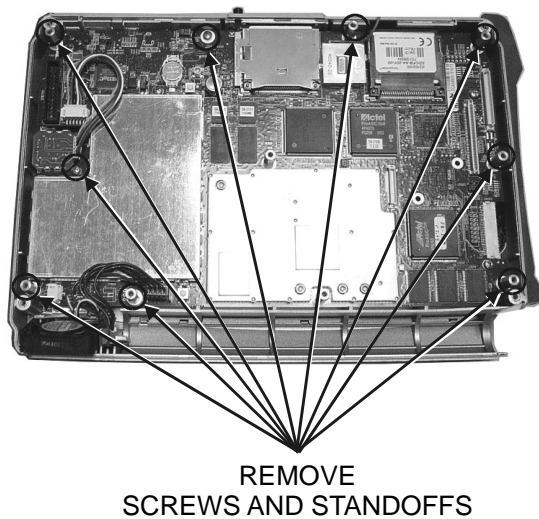

**Figure 14.** Main PCB Assembly Mounting Screws

7. Pull the Main PCB assembly down and out of the Front Panel section, taking care to slide the Compact Flash module clear of the case.
8. Replacement is the reverse of removal. Take care to insure that the connector on the Main PCB aligns with the connector on the Keypad PCB coming through the front panel.

## 7.6 LCD Assembly Replacement

This procedure provides instructions for removing and replacing the LCD assembly (15-118) once the Main PCB assembly has been separated from the VNA Master.

1. Refer to page 12, Opening the VNA Master Case and remove the back cover.
2. Refer to page 14, Removal and Replacement of the VNA Module Assembly and remove the VNA Module PCB.
3. Refer to page 16, Main PCB Assembly Replacement and remove the Main PCB assembly.
4. Use a Phillips screw driver to remove the four screws securing the LCD to the Main PCB assembly (Figure 15).

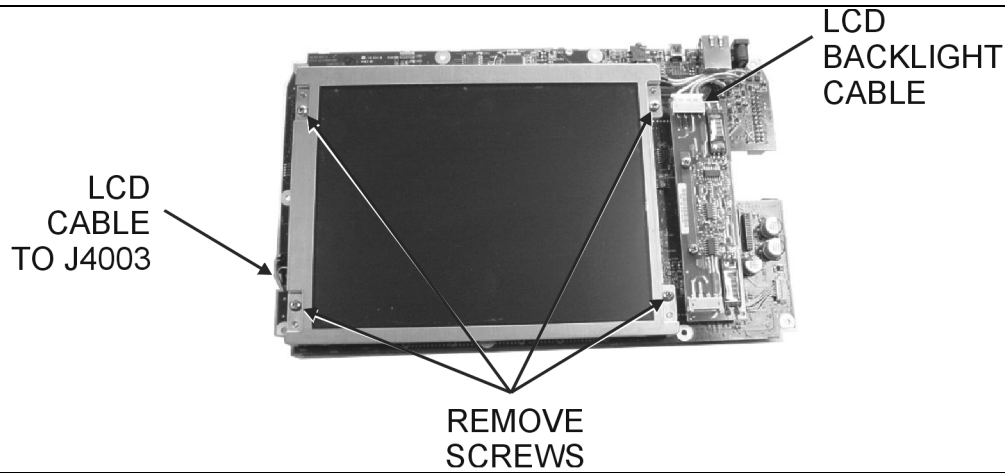

**Figure 15.** LCD Assembly Replacement

5. Disconnect the LCD backlight cable from the LCD backlight PCB.
6. Disconnect the LCD cable from J4003 on the back side of the Main PCB.
7. Carefully remove the LCD.
8. Reverse the above steps to install the replacement LCD.

**NOTE:** Pay attention to the routing of the LCD Backlight Cable. The cable must be positioned so as not to be pinched when the assembly is reattached to the front panel.

## 7.7 LCD Backlight PCB Removal and Replacement

This procedure provides instructions for removing and replacing the VNA Master LCD backlight PCB.

1. Refer to page 12, Opening the VNA Master Case and remove the back cover.
2. Refer to page 14, Removal and Replacement of the VNA Module Assembly and remove the VNA Module PCB.
3. Refer to page 16, Main PCB Assembly Replacement and remove the Main PCB assembly.
4. Disconnect the LCD backlight cable from the LCD backlight PCB (Figure 16).

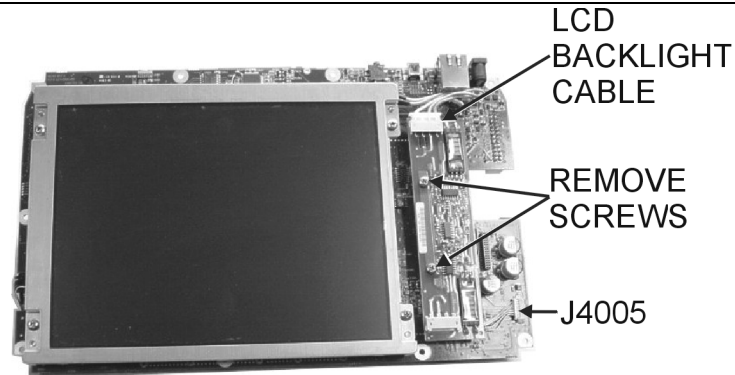

**Figure 16.** LCD Backlight PCB Removal and Replacement

5. Use a Phillips screw driver to remove the two screws securing the backlight PCB to the Main PCB assembly.
6. Lift the LCD Backlight PCB and disconnect the backlight control cable from J4005 on the Main PCB.
7. Carefully remove the LCD Backlight PCB.
8. Reverse the above steps to install the replacement LCD backlight PCB.

**NOTE:** Pay attention to the routing of the LCD Backlight Cable. The cable must be positioned so as not to be pinched when the assembly is reattached to the front panel.

## 7.8 Keypad Membrane and PCB Replacement

This procedure provides instructions for removing and replacing the keypad membrane and PCB.

**NOTE:** The keypad PCBs and membranes can be replaced without opening the VNA Master case.

1. Place the instrument face up on a protected work surface.
2. There are eight locking tabs holding the keypad bezel to the case. Using a small flat-blade screwdriver, carefully pry the front bezel locking tabs free of the main body of the case. This will expose the keypad membrane (Figure 17).

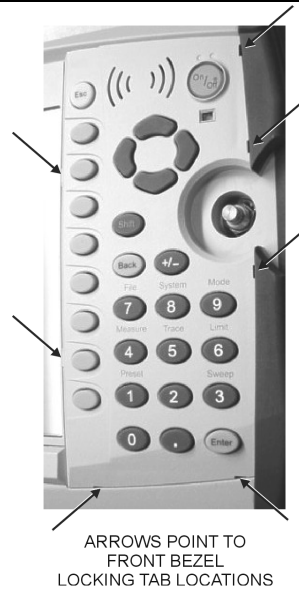

**Figure 17.** Front Panel Keypad Bezel

3. Remove the keypad membrane by carefully lifting the speaker and pulling the membrane off of the keypad PCB (Figure 18).

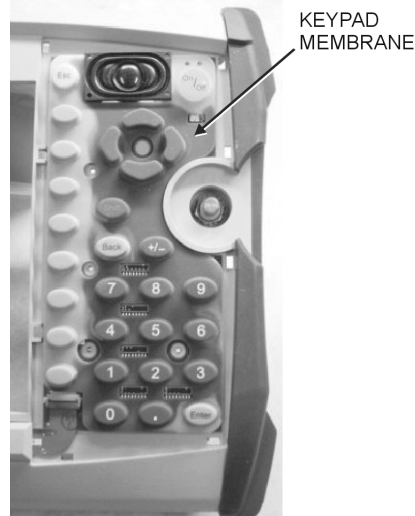

**Figure 18.** Keypad Membrane

**NOTE:** The speaker is held in place by four locating pins on the inside of the keypad bezel. When the keypad bezel is removed, the speaker is held only by the fragile connecting wires. Use care not to damage the speaker wires when removing or replacing the keypad membrane or PCB.



4. Disconnect the function key flexible switchpad from J2 of the keypad PCB by carefully lifting the locking tab on connector J2 to release the flexible switchpad (Figure 19).
- 



**Figure 19.** Keypad PCB

5. Remove the keypad PCB, taking care not to damage the speaker wires.
6. Reverse the above steps to install the replacement assembly, with the following cautions:
  - Carefully close the locking tab on connector J2 to secure the flexible switchpad connection. The tab should “snap” into position when fully closed.
  - Insert the membrane over the keypad PCB, and under the speaker. Take care to properly orient the membrane so that the rubber pins are aligned with the keypad switches on the PCB.
  - The speaker is held in place by four locating pins on the inside of the keypad bezel. Verify that the four locating pins are properly seated into the four corner holes of the speaker when reinstalling the bezel.
  - Verify that all locking tabs are fully seated into the main body of the case when reinstalling the bezel.

## 7.9 Function Key Membrane and Switchpad Replacement

This procedure provides instructions for replacing the function key membrane and switchpad.

**NOTE:** The function key PCB and membrane can be replaced without opening the VNA Master case.

1. Place the instrument face up on a protected work surface.
2. Remove the keypad bezel and membrane as directed on page 20, Keypad Membrane and PCB Replacement.
3. There are six locking tabs holding the function key bezel to the case. Using a small flat blade screwdriver, carefully pry the function key bezel locking tabs free of the main body of the case. This will expose the function key membrane.
4. Remove the function key membrane by gently pulling the membrane up and away from the front panel (Figure 20).

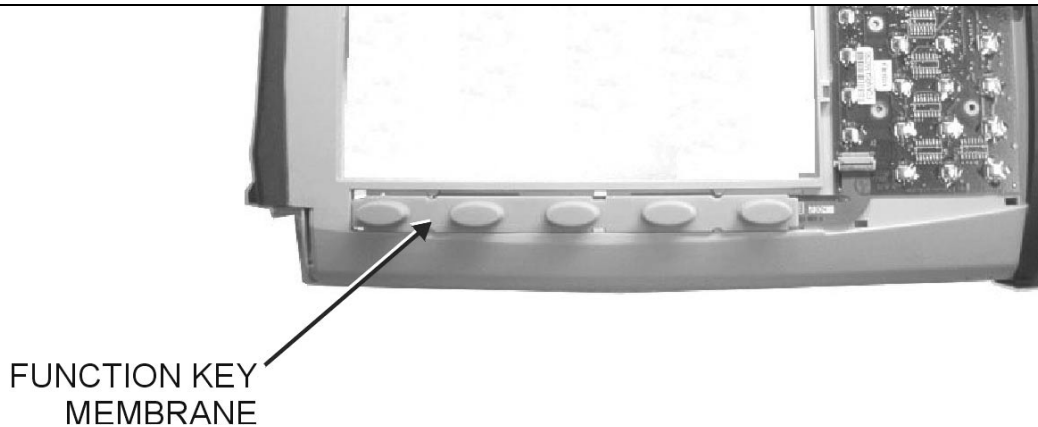

**Figure 20.** Function Key Membrane

5. Disconnect the function key flexible switchpad from J2 of the keypad PCB by carefully lifting the locking tab on connector J2 to release the flexible switchpad (Figure 21).

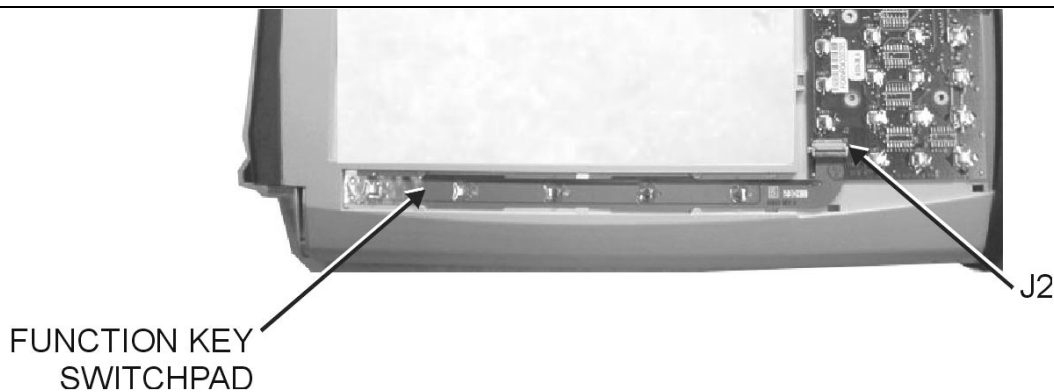

**Figure 21.** Function Key Switchpad

6. Reverse the above steps to install the replacement switchpad or membrane.

**NOTE:** Carefully close the locking tab on connector J2 to secure the flexible switchpad connection. The tab should “snap” into position when fully closed.

## 8. Accessories and Replaceable Parts List

Accessories and replaceable parts for the VNA Master MS202xA are listed below.

**Table 7.** Standard/Optional Parts List

Part Number	Description	Qty
10580-00122	User Guide, VNA Master MS202xA	1
10580-00123	Programming Manual, VNA Master MS202xA (disk only)	1
2300-498	Handheld Software Tools CD	1
40-168	AC Power Supply	1
806-141	Automotive Power Adapter	1
2000-1360	USB A-mini B Interface Cable	1
2000-1371	Ethernet Interface Cable	1
2000-1358	64 MB Compact Flash	1
1091-27	Type N male to SMA female adapter	1
1091-172	Type N male to BNC female adapter	1
61382	Soft Carrying Case	1

**Table 8.** Replacement Parts

Part Number	Description	Qty
633-44	Rechargeable Battery, Lithium-Ion	1
633-26	Lithium Coin Battery for Real Time Clock	1
ND65770	MS2024A Main PCB Assembly	1
ND65771	MS2024A Main PCB Assembly with Option 31	1
ND65780	MS2026A Main PCB Assembly	1
ND65781	MS2026A Main PCB Assembly with Option 31	1
ND65232	VNA Module Assembly	1
ND65233	Power Monitor PCB Assembly	1
61333-3	Function Key Switchpad Assembly	1
61334-3	Main Keypad PCB Assembly	1
2000-1346	Liquid Crystal Display Backlight PCB	1
15-118	Liquid Crystal Display Assembly	1
61361	Function Key Membrane	1
61362	Keypad Membrane	1

**Table 9.** Hardware Parts

Part Number	Description	Qty
905-2633P	Screw, Pan, M2 x 6, Phillips, SS, PCHL	22
905-2636P	Screw, Pan, M2.5 x 10, Phillips, SS, PCHL	27
905-2639P	Screw, Pan, M3 x 6, Phillips, SS, PCH	23
905-2640P	Screw, Flat, M3 x 6, Phillips, PCH	2
905-2642P	Screw, Pan, M3 x 12, Phillips, SS, PCHL	4
905-2663	M3 x 0.5 KEP Nut	8
905-2685	Screw, 4 MM, Phillips, SS, Shoulder	2
410-101	Encoder	1
61370-1	Cable Assembly, 3 in., INV BD	1
61371-1	Cable Assembly, 1.5 in., Display	1
61466-3	100 MHZ Coax Cable	1

**Table 10.** Case Parts

Part Number	Description	Qty
64126-2	Top Case	1
64127-2	Bottom Case	1
61379-2	Battery Door	1
61363-1	Keypad Bezel, Numeric	1
61378-1	Function Key Bezel	1
61360-2	Encoder Knob	1
61368	LCD Protective Cover	1
61381	Fan Bracket	1
ND64383	Fan Assembly	1
800-473	Battery Cable, Connector	1
61549	ID Label, Model MS2024A	1
61518	ID Label, Model MS2026A	1

## 9. Test Fixture Schematics

The following schematics are provided for those wishing to build their own test fixtures for the Option 10 verification test. The part numbers referenced in the schematics are Anritsu part numbers.

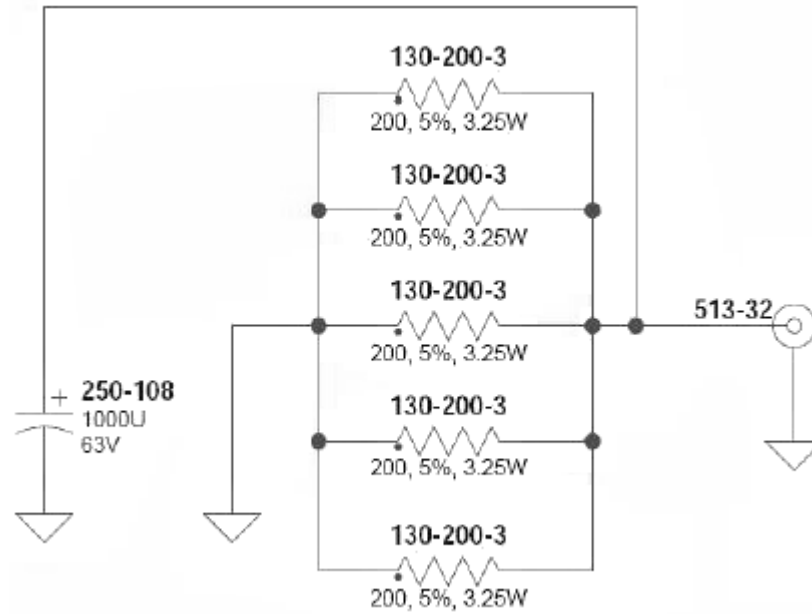

**Figure 22.** Anritsu Model T2904 High Current Test Fixture (for Option 10)

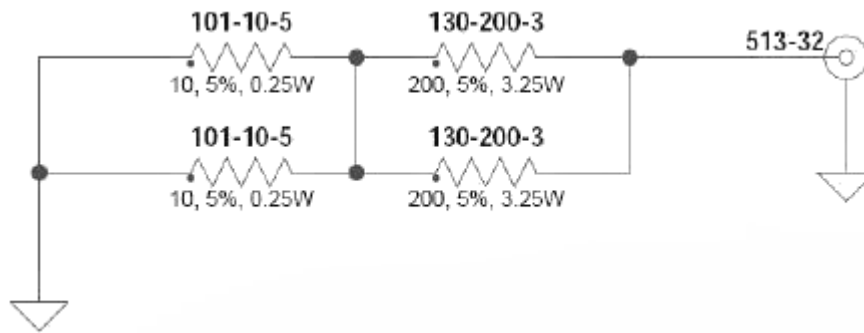

**Figure 23.** Anritsu Model T3377 Low Current Test Fixture (for Option 10)

## 10. Anritsu Customer Service Centers

**Table 11.** Anritsu Customer Service Centers

---

<b>UNITED STATES</b> ANRITSU COMPANY 490 Jarvis Drive Morgan Hill, CA 95037-2809 Telephone: (408) 776-8300 1-800-ANRITSU (267-4878) FAX: (408) 776-1744	<b>FRANCE</b> ANRITSU S.A 9 Avenue du Quebec Zone de Courtaboeuf 91951 Les Ulis Cedex Telephone: 016-09-21-550 FAX: 016-44-61-065	<b>KOREA</b> ANRITSU CORPORATION LTD. Service Center: 8F Hyunjuk Building 832-41, Yeoksam Dong Kangnam-Ku Seoul, South Korea 135-080 Telephone: 82-2-553-6603 FAX: 82-2-553-6605
<b>ANRITSU COMPANY</b> 10 New Maple Ave., Unit 305 Pine Brook, NJ 07058 Telephone: (973) 227-8999 1-800-ANRITSU (267-4878) FAX: (973) 575-0092	<b>GERMANY</b> ANRITSU GmbH Konrad-Zuse-Platz 1 Muenchen 81829 Telephone: 089-442308-0 FAX: 089-442308-55	<b>SINGAPORE</b> ANRITSU (SINGAPORE) PTE LTD. 10, Hoe Chiang Road #07-01/02 Keppel Towers Singapore 089315 Telephone: 65-6282-2400 FAX: 65-6282-2533
<b>ANRITSU COMPANY</b> 1155 E. Collins Blvd Richardson, TX 7508.1 Telephone: 1-800-ANRITSU (267-4878) FAX: (972) 671-1877	<b>INDIA</b> MEERA AGENCIES PVT. LTD. 23 Community Centre Zamroodpur, Kailash Colony Extension, New Delhi, India 110 048 Phone: 011-2644-2700/2644-2800 FAX : 011-2644-2500	<b>SOUTH AFRICA</b> ETEC SA 12 Surrey Square Office Park 330 Surrey Avenue Ferndale, Randburt, 2194 South Africa Telephone: 011-27-11-787-7200 FAX: 011-27-11-787-0446
<b>AUSTRALIA</b> ANRITSU PTY. LTD. Unit 3, 170 Foster Road Mt Waverley, VIC 3149 Australia Telephone: 03-9558-8177 FAX: 03-9558-8255	<b>ISRAEL</b> TECH-CENT, LTD. 4 Raul Valenberg St Tel-Aviv 69719 Telephone: 03-64-78-563 FAX: 03-64-78-334	<b>SWEDEN</b> ANRITSU AB Borgafjordsgatan 13 164 40 Kista, Sweden Telephone: 08-534-70700 FAX: 08-534-70730
<b>BRAZIL</b> ANRITSU ELECTRONICA LTDA. Praia de Botafogo, 440, Sala 2401 CEP22250-040, Rio de Janeiro, RJ, Brasil Telephone: 021-527-6922 FAX: 021-537-1456	<b>ITALY</b> ANRITSU Sp.A Roma Office Via E. Vittorini, 129 00144 Roma, EUR Telephone: 06-5099-711 FAX: 06-5022-425	<b>TAIWAN</b> ANRITSU CO., INC. 7F, No. 316, Section 1 NeiHu Road Taipei, Taiwan, R.O.C. Telephone: 886-2-8751-1816 FAX: 886-2-8751-2126
<b>CANADA</b> ANRITSU INSTRUMENTS LTD. 700 Silver Seven Road, Suite 120 Kanata, Ontario K2V 1C3 Telephone: (613) 591-2003 FAX: (613) 591-1006	<b>JAPAN</b> ANRITSU CUSTOMER SERVICES CO., LTD. 5-1-1 Onna Atsugi-shi Kanagawa-Prf. 243-0032 Japan Telephone: 046-296-6688 FAX: 046-225-8379	<b>UNITED KINGDOM</b> ANRITSU LTD. 200 Capability Green Luton, Bedfordshire LU1 3LU, England Telephone: 015-82-433200 FAX: 015-82-731303
<b>CHINA</b> ANRITSU ELECTRONICS (SHANGHAI) CO. LTD. 2F, Rm B, 52 Section Factory Building No. 516 Fu Te Rd (N) Shanghai 200131 P.R. China Telephone: 21-5868-0226, 5868-0227, 5868-0228 FAX: 21-5868-0588		

---



# Anritsu

Discover What's Possible®

Equipment marked with the Crossed-out Wheeled Bin symbol complies with the European Parliament and Council Directive 2002/96/EC (the "WEEE Directive") in the European Union.



For Products placed on the EU market after August 13, 2005, please contact your local Anritsu representative at the end of the product's useful life to arrange disposal in accordance with your initial contract and the local law.